

Installation Manual

SPHP/ SPXC

Single Package A/C Heat Pump





Contents

- General/Safety Information** 2
- Overview/Application Note/Inspection** 3
- General Specifications** 4-5
 - SPHP Specifications..... 4
 - SPXC Specification 5
- Removing Internal Packing Material** 6
- Before You Begin** 7-8
- Chassis Dimensions** 9
- Closet Orientations and Dimensions**..... 10
- Example Closet** 11
- Installation** 12-16
 - Installing the Plenum 12-13
 - Installing the Louver 14
 - Installing the Chassis 15
 - Installing the Access Panel..... 16
- System Start** 17
- General Wiring Diagram** 18
- Product Nomenclature**..... 19
- Warranty/Contact Information** 20



Thank you for purchasing and installing the Ice Air SPHP/SPXC (Single Package Air Conditioner and Heat Pump) Unit. Ice Air is a leading supplier of SPHP/SPXCs, offering replacement air conditioners and heat pumps that are interchangeable with units no longer available from the original manufacturer. Our units are engineered to fit perfectly within the existing wall sleeve, thereby reducing installation time and expense.

This is a general guide only, and should be treated as such. The information contained in this manual, including but not limited to installation instructions, unit dimensions, and physical/performance data, may vary by project and unit configuration. Ice Air will not be held liable for any information contained in this manual. For questions about installation and unit performance, please contact your local Ice Air representative. Installation and start-up should always be performed by a trained professional.

ATTENTION INSTALLING PROFESSIONAL

Read this manual and familiarize yourself with the specific terms and safety warnings that must be adhered to before attempting to install or service this unit. Precautions listed are intended as supplemental to existing practices. As a professional, you have an obligation to know the product better than the customer. This includes all safety precautions and related items. It is your responsibility to install the product safely and know it well enough to be able to instruct a customer in its safe use as required.

RECOGNIZE THIS SYMBOL AS A SAFETY PRECAUTION.

-  **WARNING:** Ice Air will not be responsible for any injury or property damage arising from improper service or service procedures. If you install or perform service on this unit, you assume responsibility for any personal injury or property damage which may result. Many jurisdictions require a license to install or service heating and air conditioning equipment.
-  **WARNING, HIGH VOLTAGE:** Disconnect all power before servicing or installing unit. Multiple power sources may be present. Failure to do so may cause property damage, personal injury or death.

To ensure that the unit operates safely and efficiently, it must be installed according to these installation instructions and all local codes and ordinances utilizing the best standards and practices at the time of installation, or, in their absence, with the latest edition of the National Electric Code. The proper installation of this unit is described in the following sections. Following the steps in the order presented should ensure proper installation.

Overview

Installing the SPHP/SPXC involves three main components and various accessory components.

Application Note

It is important for heating/cooling systems to be properly sized for each application in order to achieve desired temperature and humidity levels. It is highly recommended that a professional engineer match the SPHP/SPXC you are about to install with the building structure and climate.

NOTE: Pictures of components and parts may vary depending on your model.

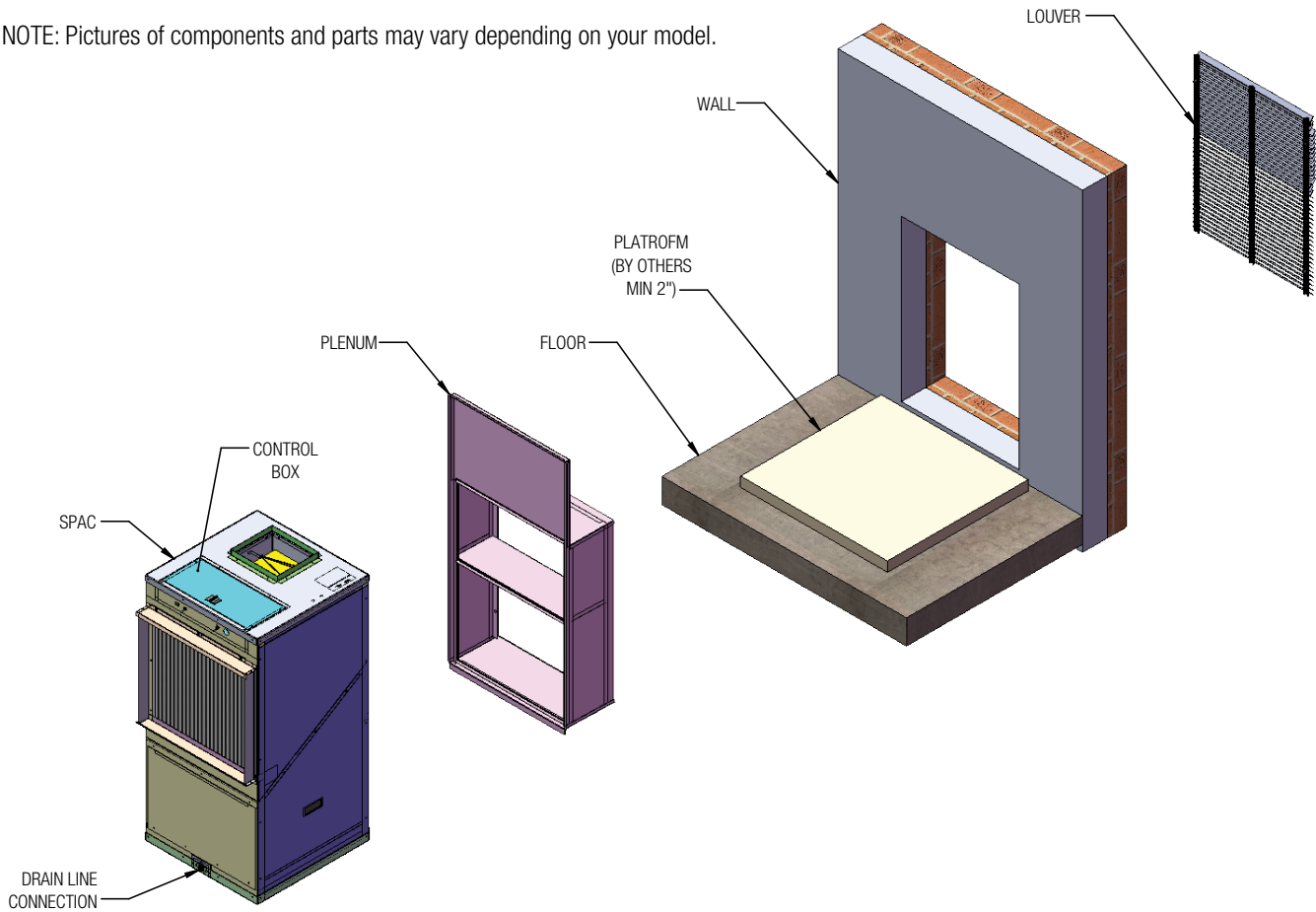

Inspection

1. Check the shipment against the Bill of Lading. Ensure all components are intact upon delivery and free from damage. Note any damage on the delivering carrier's Bill of Lading*.
2. The Ice Air unit(s) arrive prefabricated with an enclosure. Ensure both the unit and the enclosure are properly attached.
3. Make sure the floor is level in both directions so the unit's airflow will be aligned. Confirm adequate drainage is available to ensure adequate and continuous water flow during unit operation.
4. Remove the access panel is BEFORE installing.
5. Verify amperage to the unit(s) is correct and the unit can reach the power supply.

* Purchaser's responsibility includes filing all claims with the delivering carrier in a timely fashion.



General Specifications

SPHP Specifications

Model		SPHP12	SPHP18	SPHP24	SPHP30	SPHP36
Voltage	Voltage	208/230	208/230	208/230	208/230	208/230
Airflow Data	Airflow - High Speed (CFM)	400	600	800	1000	1200
Cooling Data	Total Capacity (Btu/hr) ¹	11,500	16,800	24,000	27,500	32,500
	Sensible Capacity (Btu/hr) ¹	8,630	12,600	18,000	22,500	24,900
	EER ¹	13.0	11.0	11.0	11.0	11.0
	Current (Amps)	4.3	7.3	10.4	12.0	14.2
	Power (Watts)	884	1,527	2,182	2,500	2,955
Heat Pump Data	Capacity (Btu/hr) ²	11,400	15,200	19,000	24,000	27,500
	COP ²	3.5	3.3	3.3	3.3	3.3
	Current (Amps)	4.6	6.5	8.1	10.2	11.7
	Power (Watts)	955	1,350	1,687	2,130	2,441
Electric Heat Data	Electric Heater (kW) ³	3.5 5.0	5.0 7.5	5.0 7.5	5.0 7.5	5.0 7.5
MCA/MOCP	MCA (with Electric Heat)	22.5 27.8	28.7 47.4	28.9 47.8	29.5 48.3	33.3 48.3
	MOCP (with Electric Heat)	25 30	30 50	30 50	30 50	40 50
	MCA (without Electric Heat)	10.8	13.3	21.1	23.8	29.4
	MOCP (without Electric Heat)	15	20	30	30	40
Physical Data	Chassis Dimensions (W x D x H)	23 x 23 x 47		28 x 26 x 64		
	Net Weight (lbs)	180	180	225	320	320

Specification Notes:

1. Rated performances in cooling mode @ 80F/67F DB/WB Indoors and 95F/75F DB/WB Ambient
2. Rated performances in heating mode @ 70F/60F DB/WB Indoors and 47F/43F DB/WB Ambient
3. Emergency back-up electric heater is offered as a factory installed option.



General Specifications

SPXC Specifications

Model	SPXC12	SPXC18	SPXC24
Cooling Capacity (Btu/hr) 1	11,200	16,800	24,000
Sensible Capacity (Btu/hr) 1	9,900	12,900	18,500
Cooling Capacity Range (Btu/hr)	9,700 - 16,700	10,500 - 19,500	13,900 - 25,600
EER 1	13.0	11.0	11.0
Cooling Operating Range	38°F TO 115°F		
Cooling Input (Watts)	862	1,527	2,182
Cooling Input (Amps)	4.1	7.3	10.4
Heating Capacity (Btu/hr) 2	11,400	15,200	21,000
Heating Capacity Range (Btu/hr)	7,600 - 14,200	11,500 - 19,200	15,100 - 25,900
COP 2	3.5	3.3	3.3
HSPF 2	9.0	9.0	9.0
Heating Outdoor Operating Range	-5 F TO 70 F		
Heating Input (Watts)	955	1350	1,865
Heating Input (Amps)	4.6	6.5	9
Electric Heat (kW)	3.5 5.0	5.0 7.5	5.0 7.5
Voltage	208	208	208
MCA (without Electric Heat)	9.8	14.8	18.8
MOP (without Electric Heat)	15	20	25
MCA (with Electric Heat)	22.5 27.8	28.7 47.4	28.9 47.8
MOP (with Electric Heat)	25 30	30 50	30 50
Airflow (CFM)	400	600	800
Outside Air (CFM)	60	60	60
External Static Pressure - ESP (in.wg.)	0.3	0.3	0.3
Weights (lbs.)	220	260	360
LOW AMBIENT PERFORMANCE			
Heating Capacity @ 10°F	7,100	10,700	17,400
COP @ 10°F	2.04	1.99	2.18
Heating Capacity @ 5°F	6,800	10,300	16,200
COP @ 5°F	1.86	1.82	1.99
Heating Capacity @ -5°F	5,100	8,000	15,800
COP @ -5°F	1.52	1.5	1.72

Specification Notes:

1. Rated performances in cooling mode @ 80°F/67°F DB/WB Indoors and 95°F/75°F DB/WB Ambient
2. Rated performances in heating mode @ 70°F/60°F DB/WB Indoors and 47°F/43°F DB/WB Ambient
3. If the electric heat option is selected, the heat pump operation is disabled and electric heat enabled below -5°F (+/- 3 °F)
4. Units without electric heat will operate below -5°F with derated performance. Performance below -5°F has not been certified.

Removing Internal Packing Material

1. Open carton box with “PLEASE REMOVE INTERNAL PACKAGE MATERIAL BEFORE OPERATION” label.



2. Remove two sheet metal side panels with “PLEASE REMOVE INTERNAL PACKAGE MATERIAL BEFORE OPERATION” labels attached



3. Carefully remove five pieces of internal packing material as labelled in the image below.

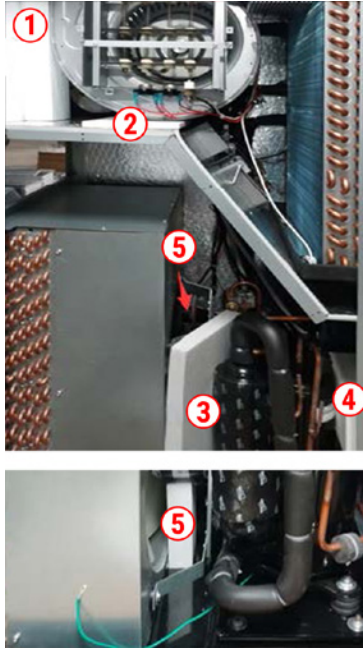

4. Clean any foam packing debris that may have broken off as packing was removed.

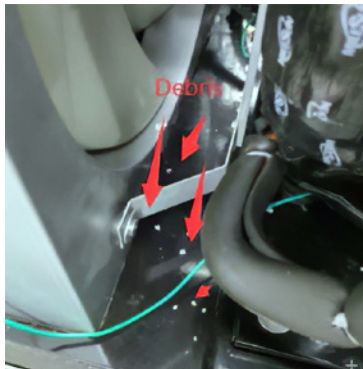

5. Reinstall side sheets, making sure the slot of the lower sheet clamps into the edge of drain pan as shown in the image below.

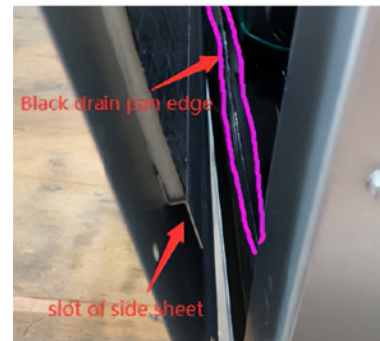
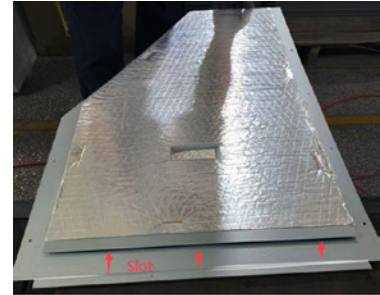

6. Remove the “PLEASE REMOVE INTERNAL PACKAGE MATERIAL BEFORE OPERATION” labels on the side metal sheets.
7. Remove the “PLEASE REMOVE INTERNAL PACKAGE MATERIAL BEFORE OPERATION” label on the power line area.



Before You Begin

1. For proper operation, install the SPHP/SPXC unit on an outside wall.
2. Avoid confined spaces and covered areas, as these will interfere with proper operation of the unit. Make sure to place the unit where it can easily distribute air throughout the room with no obstructions.
3. If two units are to be placed side by side, install them no closer than 12" apart.
4. Make sure to leave a vertical clearance of 60" between SPHP/SPXC units.
5. If the SPHP/SPXC unit is installed on the bottom floor, be sure to mount the unit at a minimum of 6" off of the ground.
6. Ensure the wall is structurally sound to support the weight of the unit.
7. Ensure adequate drainage is available.
8. Follow all applicable codes for installation.
9. Verify the amperage of the dedicated electrical service to the unit is correct and the unit can reach the proper power supply.
10. Position the SPHP/SPXC so the air filter can be removed easily and required maintenance can be performed without interference.
11. A minimum obstructed distance of 36" should be kept around the unit.

TOP VIEW

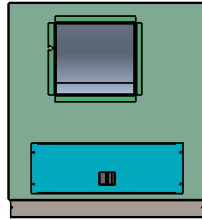

ISOMETRIC VIEW

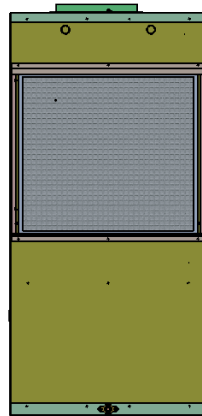
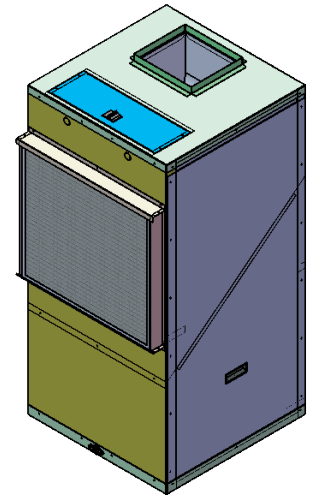

FRONT VIEW

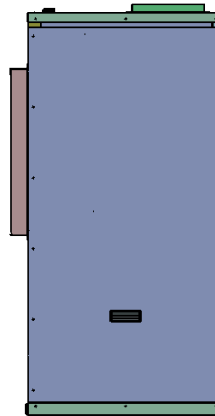

RIGHT VIEW

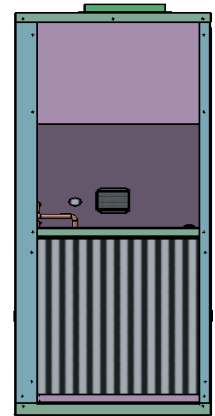

REAR VIEW

IMPORTANT: To avoid permanent damage to the unit, DO NOT operate during construction in an open space or as a supplemental heating and cooling source during construction.

1. Once you've determined the proper location, create a wall opening to install the wall panel. Check measurements against the Unit dimensions (See Before You Begin).
2. Before installing the unit, check the wall opening to be sure the wall panel will slide into place unobstructed.
3. For masonry walls, a lintel must be used to provide support over each opening.

NOTE: Installer must determine and supply the mounting bolts and/ or screws to attach the wall sleeve to the sides of the wall opening. Make sure the wall opening is adequate for strong support.

Electrical Information and Requirements

1. Ensure that available power is the same voltage and phase as indicated on the unit serial plate. Line and voltage wiring must be executed in accordance with local codes or to the National Electrical Code or in Canada to Canadian Electrical Standards.
2. Apply correct line voltage to unit. Disconnect switch near unit is required by code. Power to unit must be sized correctly and have dual element class RK5 fuses or HACR circuit breaker for branch circuit overcurrent protection. Consult the unit serial plate for current ratings.
3. All 208/230V units are wired for 208V operation unless otherwise specified.
4. All units must be hard-wired.

▲ WARNING: Take Proper Precautions to Avoid Electrical Shock. To minimize hazards and the potential of electrical shock, all electrical work should be performed by a qualified electrician in accordance with the National Electrical Code (NEC) and any applicable local codes. Failure to follow proper safety guidelines can result in property damage, personal injury and/or death.

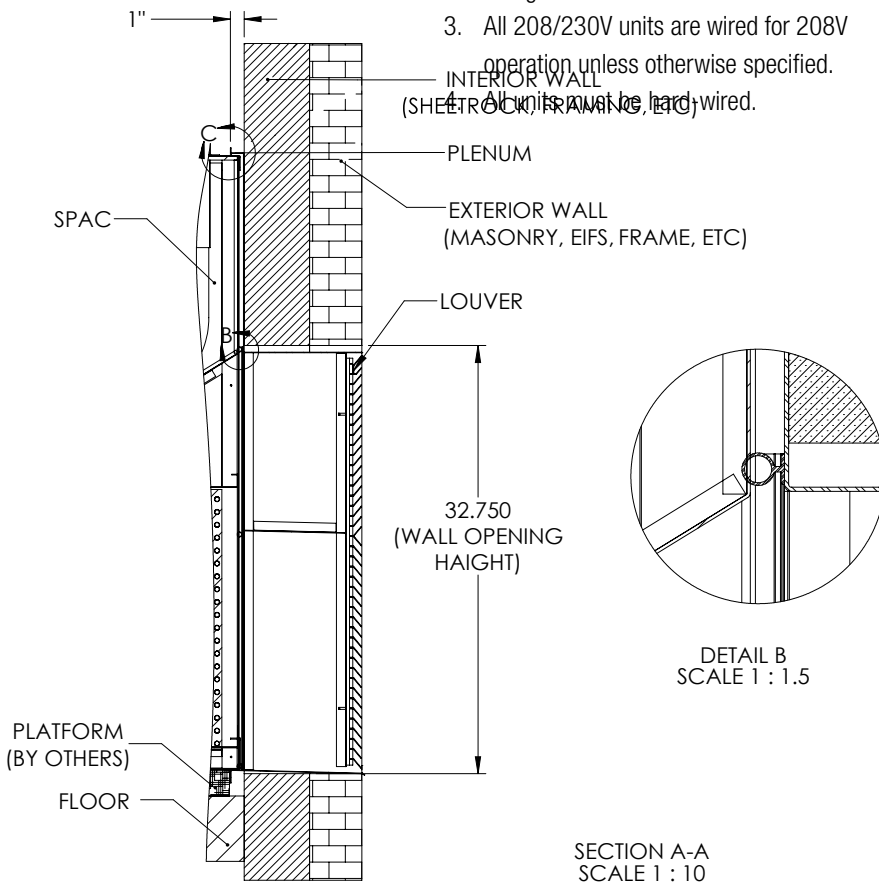

UNIT SIZE	Wall opening height (inches)	
	H	
12/18	33	
24/30/36	WALL	44

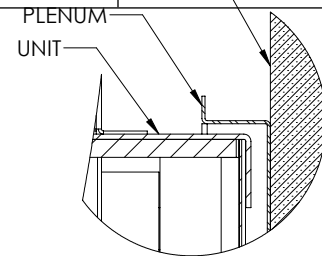

DETAIL C
SCALE 1 : 2

Chassis Dimensions

UNIT SIZE	Dimensions (inches)									
	A	B	C	D	E	F	G	H	J	
12	47	23	23	8 1/2	9 1/2	2 1/4	8 1/4	20 1/2	11 1/2	
18	47	23	23	8 1/2	9 1/2	2 1/4	8 1/4	22 1/2	9 1/2	
24/30/36	64	26	28	10 5/8	9 1/2	2 1/4	8	32 1/2	10 1/4	

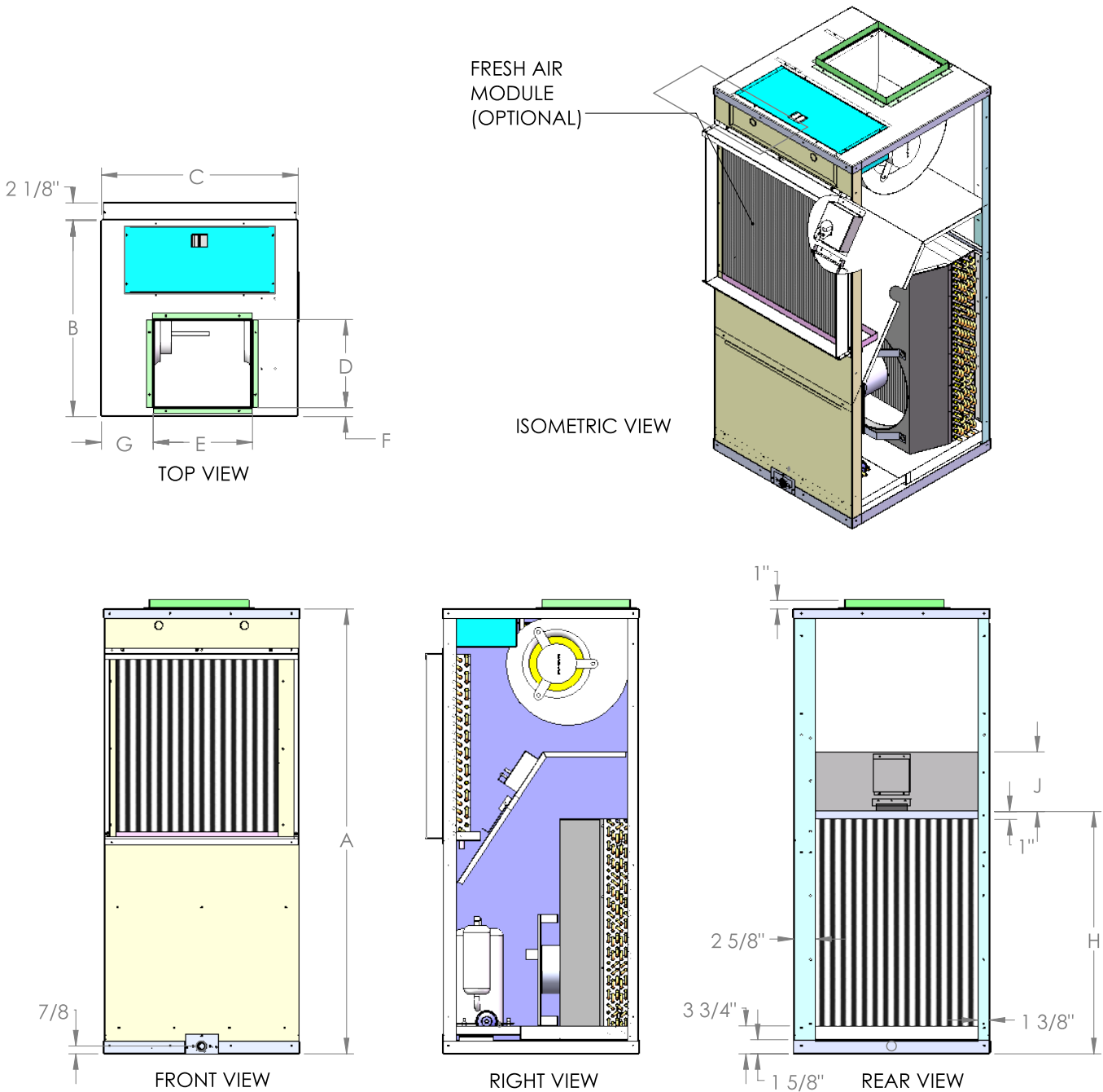

Due to Ice Air's ongoing product development programs, the information in this document is subject to change without notice.

Closet Orientations and Dimensions

SPHP 12/18 & SPXC 12/18 Front Oriented

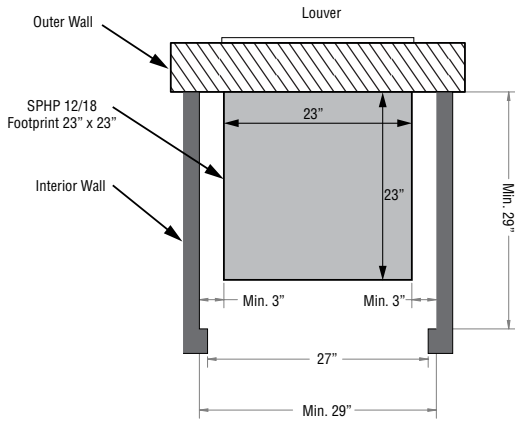

SPHP 24/30/36 & SPXC 24 Front Oriented

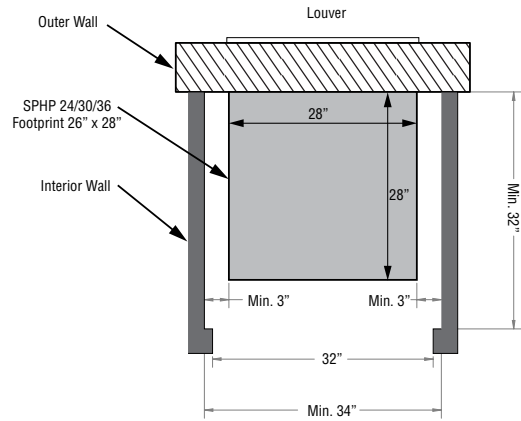

SPHP 12/18 & SPXC 12/18 Left Oriented

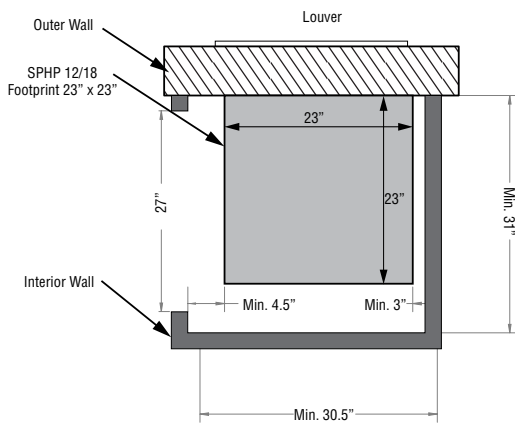

SPHP 24/30/36 & SPXC 24 Left Oriented

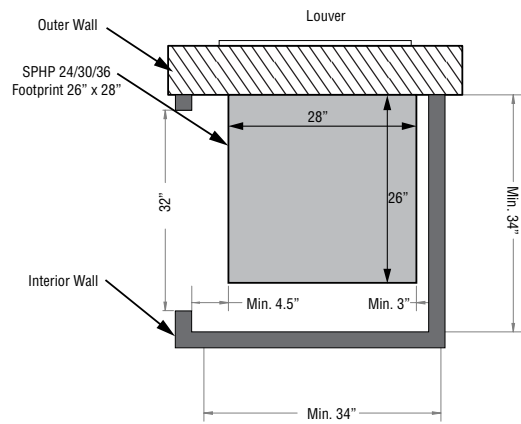

SPHP 12/18 & SPXC 12/18 Right Oriented

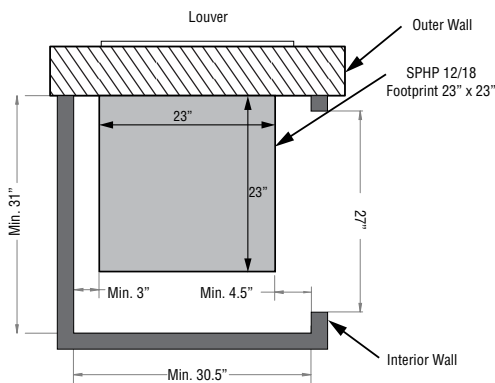

SPHP 24/30/36 & SPXC 24 Right Oriented

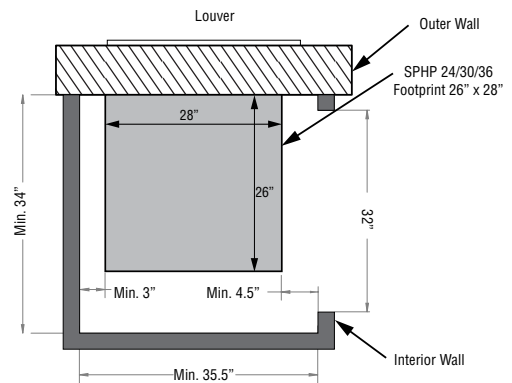

Note about Clearance Requirements:

Proper clearance must be maintained around the unit. The guidelines shown above are minimums. It is recommended to have additional clearance for ease of access and service.

Due to Ice Air's ongoing product development programs, the information in this document is subject to change without notice.

Example Closet

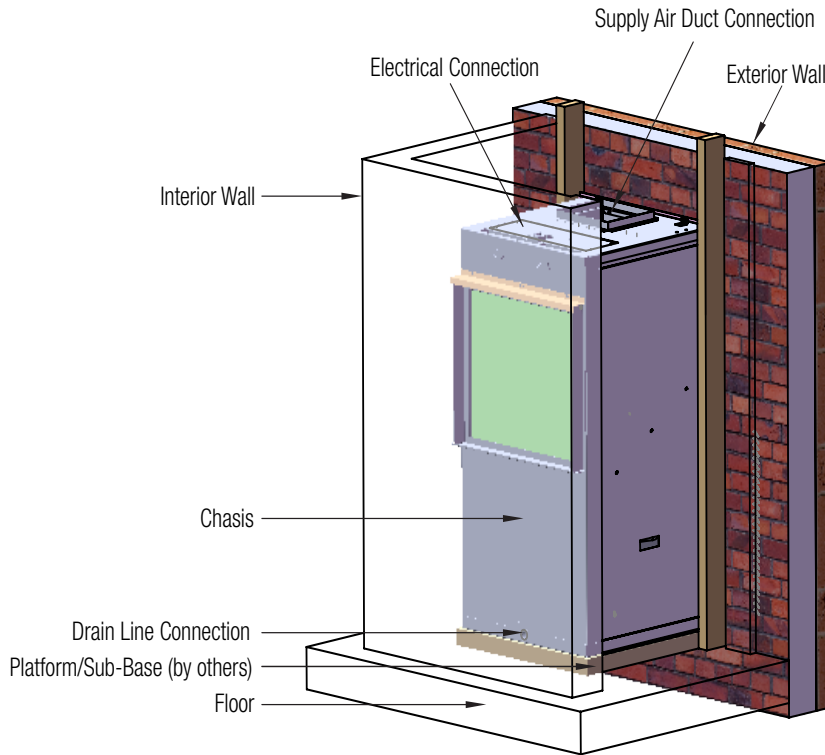

NOTE: Access door, plenum, and outdoor louver not shown in this image. Additional components may be required.

Installation

Installing the Plenum

NOTE: The plenum must be installed properly for optimal performance. It is important to make sure that the orientation of the plenum is correct before completing installation.

Provided Parts

1. Outside Plenum Assembly: For correct orientation, the louver attachment flanges should be positioned toward the outside of the building, with the drip ledge at the bottom.
2. Inside Plenum Assembly: For correct orientation, position the opening to the bottom 3/4" section of the flange toward the inside of the building.

Field-Supplied Materials

1. 1" -3" Screws
2. Shim
3. Flashing
4. Caulk
5. Header Materials/Wall Studs

Plenum Installation Instructions

1. Measure the outside wall.
2. Cut, frame and square the rough opening.
3. Cover the rough opening and/or shim with the plenum's 3/4" break.
4. Build a header opening into the rough opening.
NOTE: It is the installer's responsibility to correctly and safely install the plenum, while meeting any and all national, local and building code requirements. DO NOT use the plenum to support structural loads.
5. Install the louver onto the outside plenum assembly. For best results, do this before installing the plenum.
6. Install anchor screws without penetrating the top or bottom of the plenum. Anchor screws should be placed four inches from the top and bottom of the plenum.
7. After the rough cut opening is prepared, dry fit the outside plenum assembly into the rough opening. Verify that fit and leveling are correct before proceeding with caulk.
8. Apply caulk to the inside and outside assembly parts.
9. Caulk all flange corners and holes.
10. Caulk the outside plenum assembly and insert into the opening.
11. Caulk and insert the inside plenum assembly into the outside assembly. Check to verify that the outside assembly stays firm without backing out of the wall opening.
12. Adjust the divider by loosening the two screws on the divider's top side.
13. Reposition the top section of the divider by sliding toward the outside. Stop when the sealing strip touches the outside louver.
14. Complete adjustment by tightening the divider screws.

SPHP 12/18 & SPXC 12/18 Wall Plenum

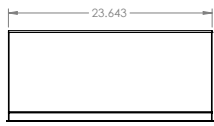

TOP VIEW

NOTE:

1. RECOMMENDED OPENING IN THE WALL FOR PLENUM IS 24.250"W x 33.000"H.
2. BOTTOM OF THE WALL PLENUM SHOULD BE INSTALLED A MIN OF 4" OFF OF THE FINISHED FLOOR.

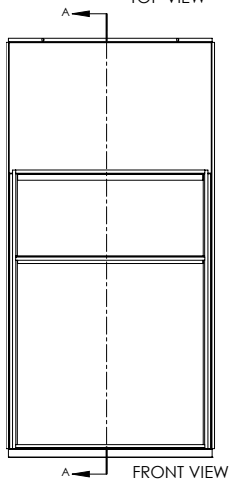

FRONT VIEW

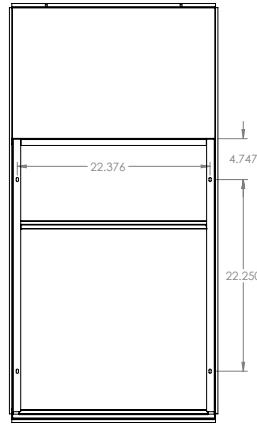
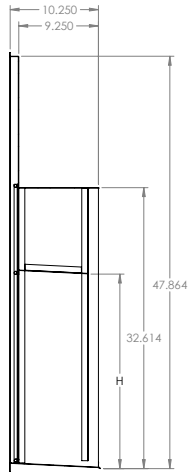

REAR VIEW

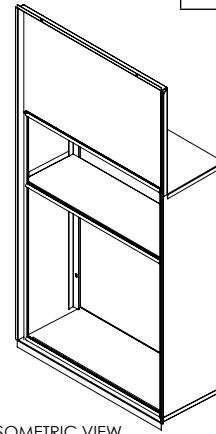

ISOMETRIC VIEW

UNIT SIZE	Dimensions (Inches)	
	H	
12	20.488	
18	22.582	

SPHP 24/30/36 & SPXC 24 Wall Plenum

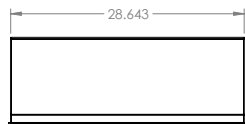

TOP VIEW

NOTE:

1. RECOMMENDED OPENING IN THE WALL FOR THE PLENUM 29.250"W x 44.000"H.
2. WALL PLENUM SHOULD BE INSTALLED A MIN 5" OFF OF THE FINISHED FLOOR

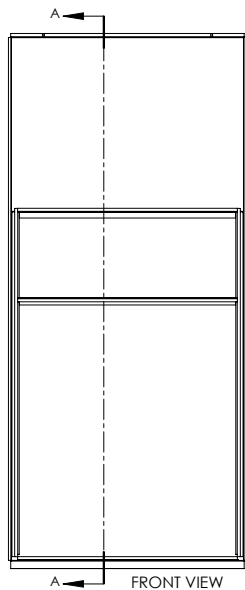

FRONT VIEW

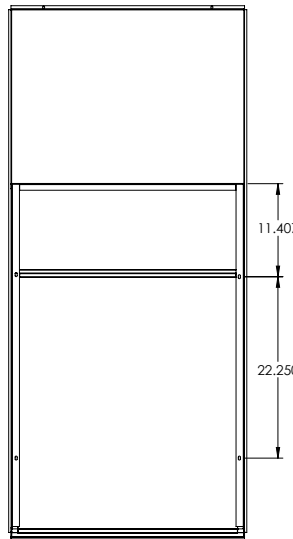
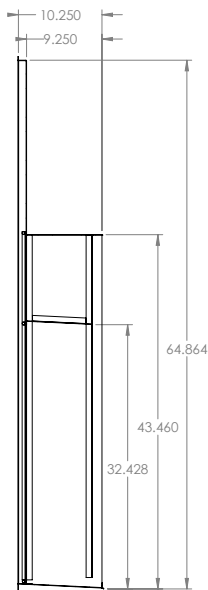

REAR VIEW

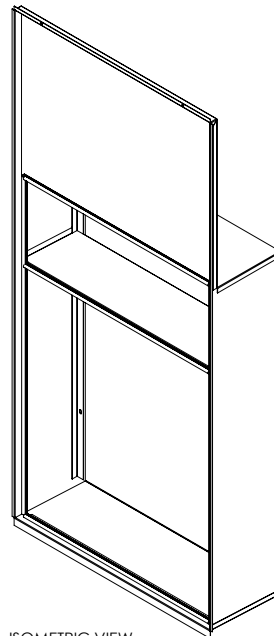

ISOMETRIC VIEW

Installing the Louver

The louver directs condenser airflow and provides a protective barrier for the outdoor coil.

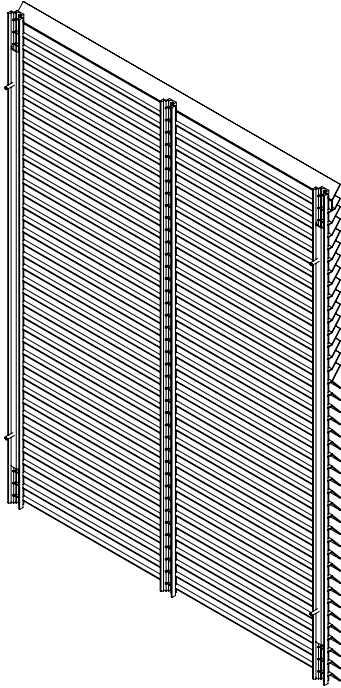

SPHP 12 & SPXC 12 Louver

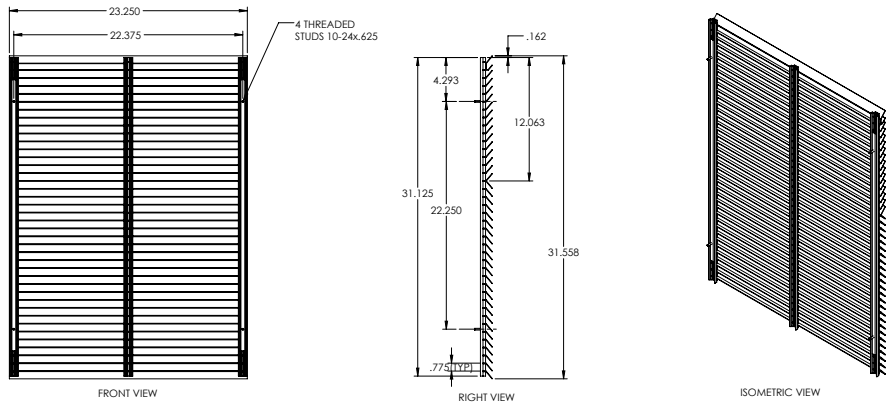

SPHP 18 & SPXC 18 Louver

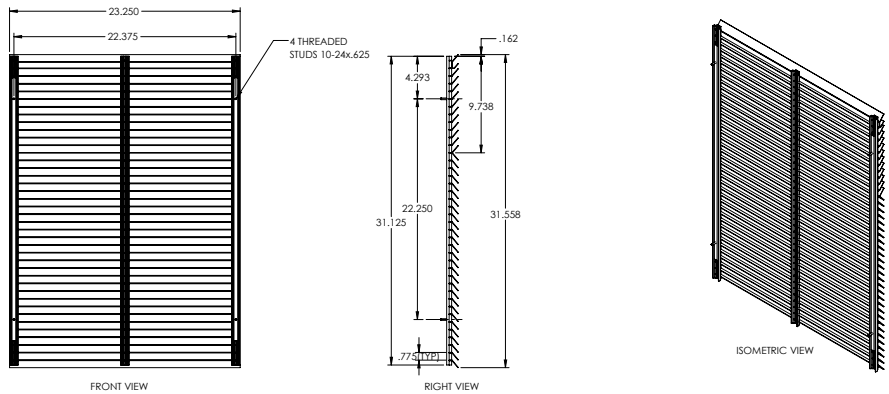

IMPORTANT: Depending on the size and style of the louver chosen, you should determine whether it can be installed before or after the sleeve installation.

1. Install four threaded studs into threaded openings on the inside face of the louver.
2. Install a washer and one hex nut to the end of each stud.
3. Manipulate the louver out through rear wall sleeve opening. Keep a firm grip on louver to prevent causing possible injury or property damage.
4. Attach the louver to the wall sleeve by aligning and inserting the hex nut threaded onto the studs through the holes in the wall sleeve.
5. Secure the louver to the wall sleeve by tightening the hex nut and adding and tightening an additional hex nut.

SPHP 24/30/36 & SPXC 24 Louver

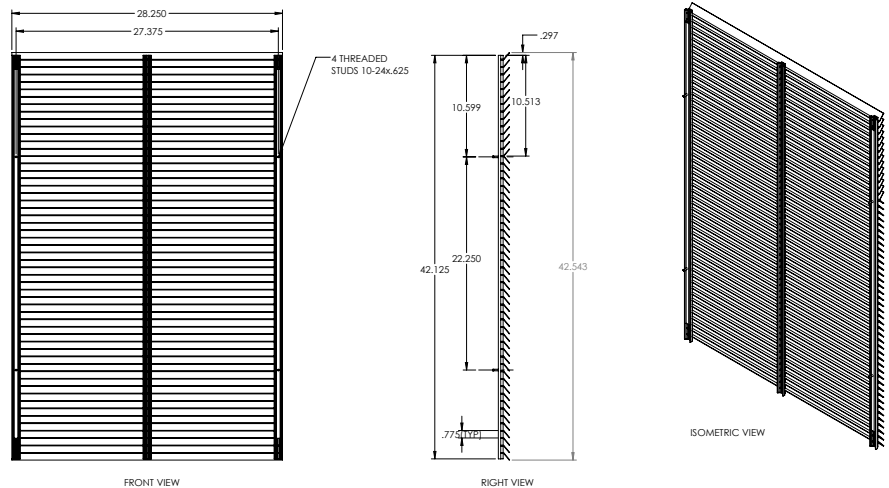

Installing the Chassis

1. Before beginning installation of the chassis, make sure that the plenum is correctly installed (see Plenum and Louver Installation for details).
2. Place the chassis into the closet. For correct orientation, the outer side of the chassis should face the plenum opening.
3. Slide the chassis into the plenum to form the plenum divider seal.
4. Make all final connections to ductwork and condensate drain.

NOTE: For correct installation, the plenum divider gasket should make contact with the plastic condenser baffle.

Closet Orientations and Dimensions

Unit Front Access

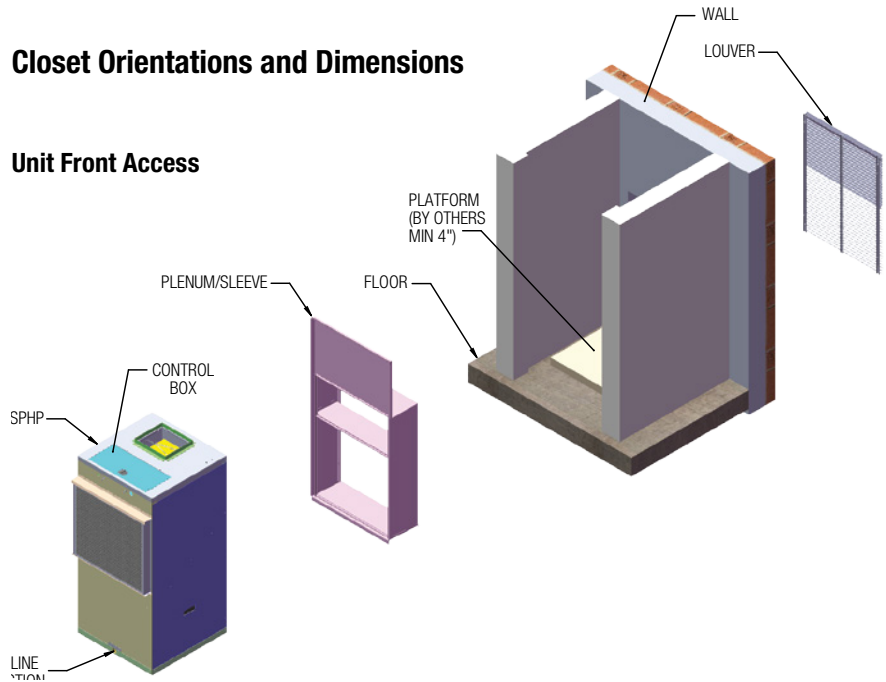

Unit Right Access

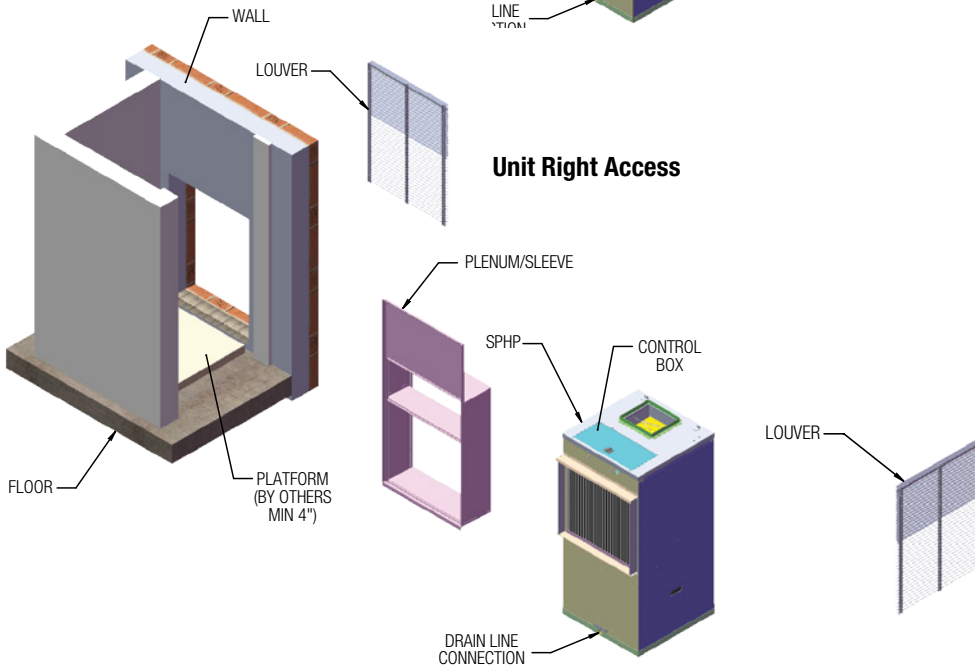

Unit Left Access

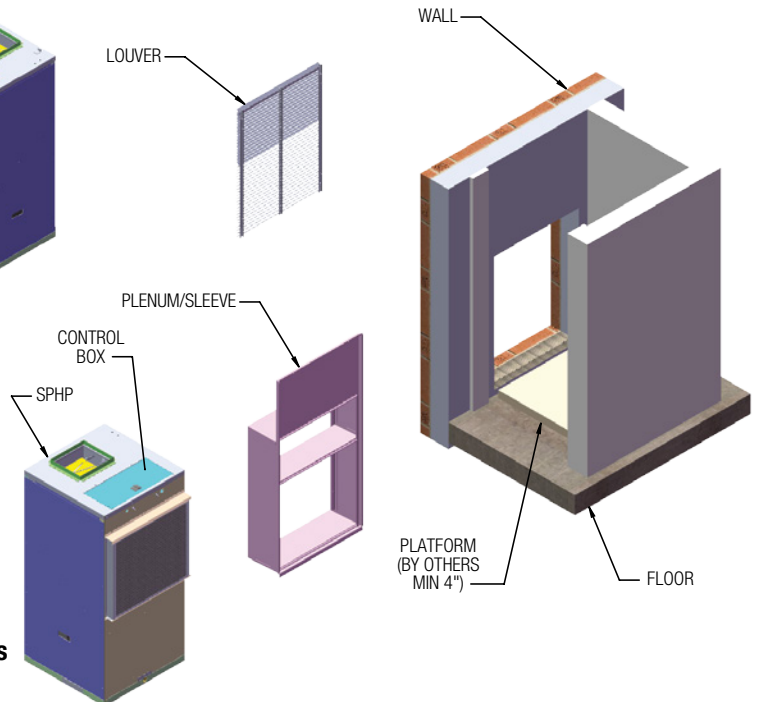

Installing the Access Panel

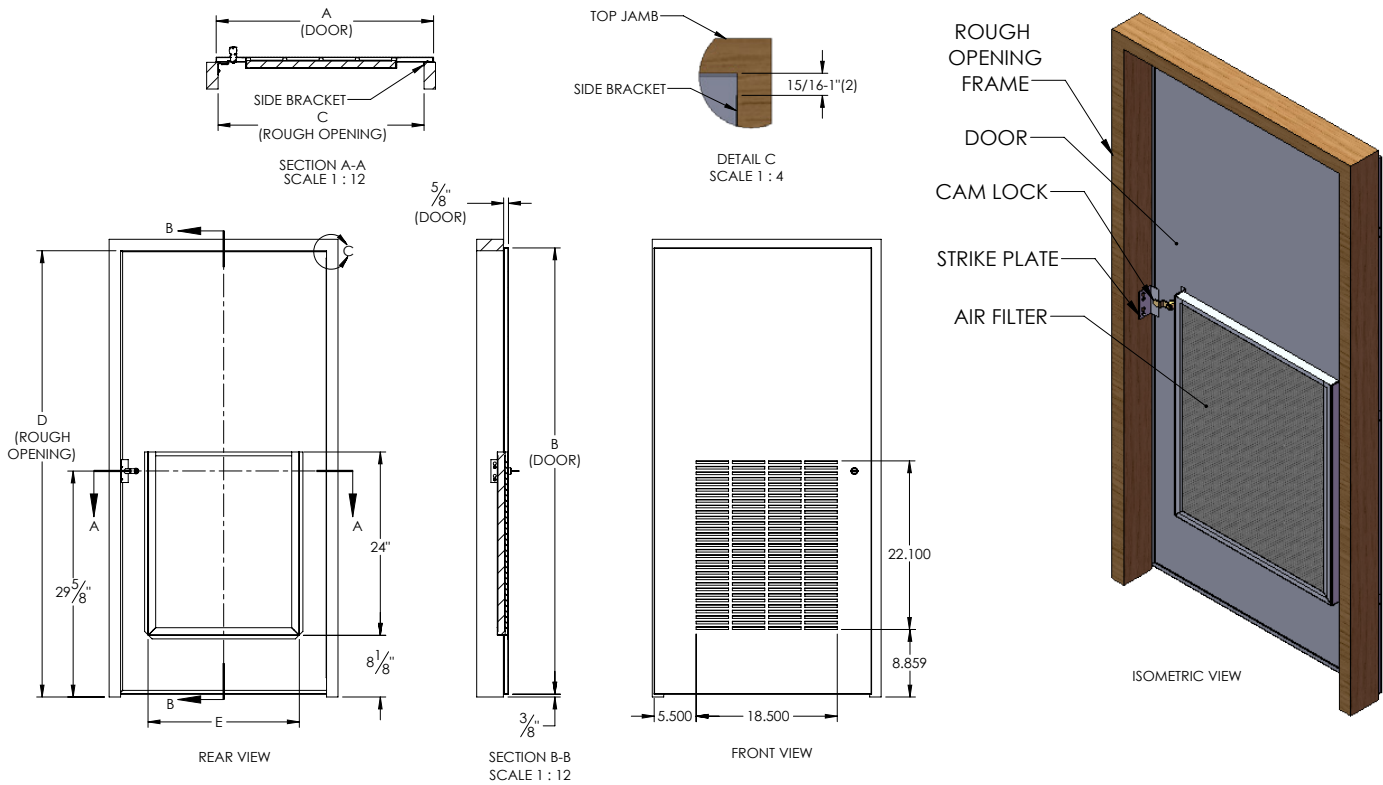

NOTE.

1. ACCESS DOOR IS LHR.
2. MOUNT SIDE BRACKET ON LEFT JAMB OF FRAME WITH DIM. 15/16-1" FROM TOP JAMB AND SECURE IT WITH SCREWS.
3. HANG ON TABS OF SIDE BRACKET THE DOOR, CLOSE IT AND MOUNT STRIKE PLATE ON OPPOSITE SIDE OF FRAME.
4. ADJUST POSITION OF STRIKE PLATE ACCORDING POSITION OF CAM LOCK AND SECURE WITH SCREWS.

	Dimensions (inches)				
	A	B	C	D	E
01	28.5	58.5	27	58.5	20
02	33.5	70.5	32	70.5	24



System Start

Start-Up Preparation

Prior to start up, ensure that all unit and system components are in good condition. The manufacturer will not be held liable for any damage incurred due to improper system checkout or improper start-up procedure. Startup should only be performed by a certified licensed technician.

Inspect each unit individually, ensuring the following conditions have been met.

Pre-Startup Checklist:

1. Power is supplied to unit.
2. Clean filter is installed.
3. Thermostat is installed.
4. Unit is properly secured.
5. Ductwork is properly attached.
6. Condensate line is open and free of debris.

Start-Up Procedure:

1. Turn on power to the unit.
2. Set thermostat mode to "Cool." Wait several minutes. Check for cold air delivery at registers.
3. Set thermostat mode to "Heat." Wait several minutes. Check for hot air delivery at registers.

Startup Checklist:

1. Compressor comes on.
2. Fan speed works properly in cooling mode.
3. Fan speed works properly in heating mode.

General Wiring

SPHP Wiring

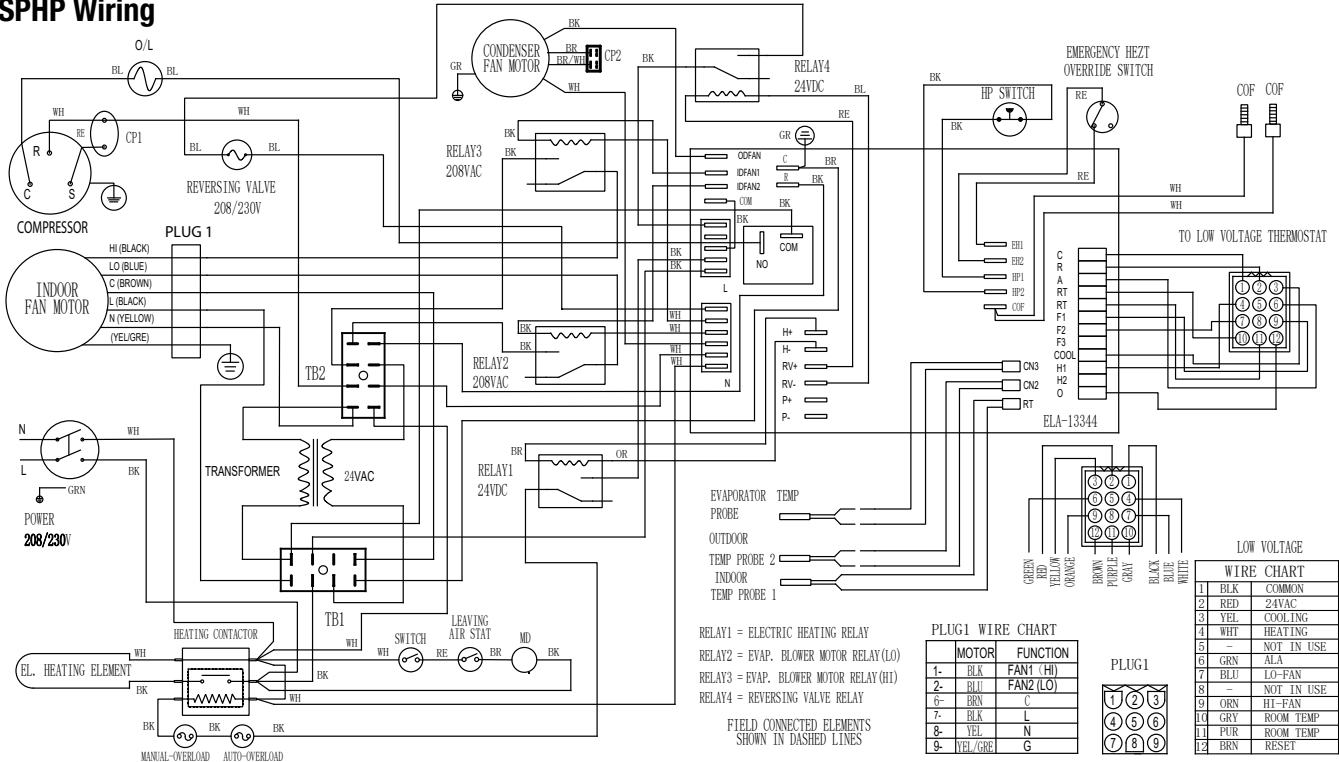

SPXC Wiring

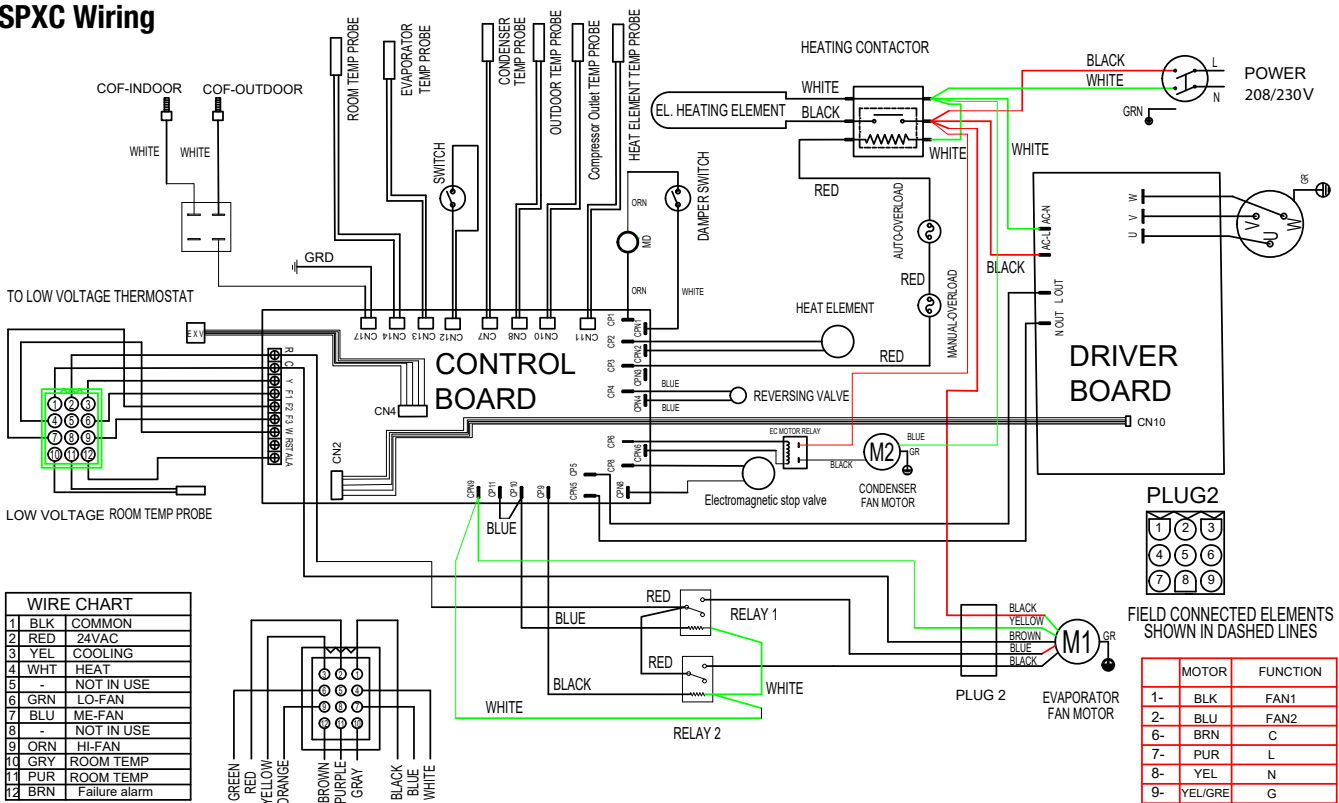

Due to Ice Air's ongoing product development programs, the information in this document is subject to change without notice.



Product Nomenclature

Model Selection **8 SPHP/SPXC 12 35 EP N F F 1 C B A X**
 1 2 3 4 5 6 7 8 9 10 11 12 13
 Primary Part

Item #	Matrix Name	Code String Value	Description
1	POWER	8	208-230V/1Ph/60Hz
		7	265-277V/1Ph/60Hz
2	UNIT TYPE	SPHP	Single Packaged Heat Pump
		SPXC	Single Packaged Heat Pump
3	CAPACITY (BTUH)	12	12,000 Nominal (1-Ton)
		15	15,000 Nominal (1-1/4-Tons)
		18	18,000 Nominal (1-1/2-Tons)
		24	24,000 Nominal (2-Tons)
		30	30,000 Nominal (2-1/2-Tons)
		36	36,000 Nominal (3-Tons)
4	BACKUP E-HEAT	XX	No Backup Electric Heat
		30	3.0-kW Backup Electric Heat
		35	3.5-kW Backup Electric Heat
		50	5.0-kW Backup Electric Heat
		60	6.0-kW Backup Electric Heat
5	MOTOR	EP	EC Evaporator Motor, PSC Condenser Motor
		EE	EC Evaporator and Condenser Motor
6	ELECTRICAL CONNECTION	N	Non-Fused Disconnect
		F	Fused Disconnect
		L	Line Cord
		J	Junction Box
		S	Power Strip
7	CONTROLS	X	None
		C	Non-Programmable LCD Touchpad Thermostat (ELA-12690)
		D	Non-Programmable LCD Thermostat (ELA-8842 via dip switch)
		E	7-Day Programmable LCD Thermostat (ELA-8842)
		F	7-Day Programmable Touchscreen Thermostat (ELA-13086)
		G	Nest Thermostat (ELA-10665)
		H	Habitat Wireless Wi-Fi Thermostat with Water Leak Detector (ELA-13161)
8	WIRE WHIPS	I	Non-Programmable LED Touchpad Thermostat (ELA-10328)
		X	Thermostat Field Mounted By Others
		A	6.5' Wire Whip for Remote Mounted Thermostat
		B	10' Wire Whip for Remote Mounted Thermostat
		C	12' Wire Whip for Remote Mounted Thermostat
		D	30' Wire Whip for Remote Mounted Thermostat
9	INSULATION	E	50' Wire Whip for Remote Mounted Thermostat
		F	Standard 18" Wire Whip
		U	Unit Mounted Thermostat

Item #	Matrix Name	Code String Value	Description
9	INSULATION	1	Standard Insulation
		2	Thick Internal Insulation
10	DAMPER	X	No Damper
		B	Manual Damper
		C	Motorized Damper
		F	Motorized Damper with Outside Air Module
11	COND. OVERFLOW SWITCH	C	Condensate Overflow Switch - Condenser Only
		E	Condensate Overflow Switch - Evaporator Only
		B	Condensate Overflow Switch - Evaporator and Condenser
		S	External Condensate Overflow Switch
		X	No Condensate Overflow Switch
12	FILTER	A	MERV 8 Filter
		C	MERV 13 Filter
		W	Washable Filter
		P	Fiberglass filter
		X	No Filter
13	COMPRESSOR BLANKET	B	Sound Attenuation Blanket
		X	No Compressor Blanket

Limited Warranty

Twelve (12) Month Warranty of entire Packaged Terminal Equipment

Ice-Air, LLC ("Ice Air" or the "Company") warrants, solely to the person or entity that directly purchased the packaged terminal system from the Company (the "Original Owner"), that the entire packaged terminal system is free from defects in material and workmanship for a period of twelve (12) months from the date of delivery (the "Twelve Month Warranty"). Any part or portion thereof which becomes defective under normal use during the period of this warranty will be repaired or replaced, provided Ice Air's examination shall prove to its satisfaction that the part was or became defective under normal use. Ice Air's obligations under this warranty are subject to the satisfaction of the conditions set forth in the last paragraph of this Section and are limited to: (a) repairing the defective part or (b) furnishing a replacement part provided the defective part is returned to Ice Air, without shipping damage, transporting charges prepaid. No reimbursement will be made for expenses incurred in making field adjustments or replacements unless specifically authorized in writing by the Company.

Except as otherwise provided in the last sentence of this paragraph, the Company is not obligated under this warranty for field labor such as service for inspection, removing, packing and/or reinstalling water source unit, nor for the return transportation charges. In addition, the Company is not obligated under this warranty to make reimbursement of the labor or service charges of any other party. Notwithstanding the foregoing, labor provided by or at the direction of the Company during the twelve (12) month period from the date of delivery referred to in the initial paragraph above, in connection with the Twelve Month Warranty of parts provided in the initial paragraph above, is included in such warranty, solely in the case in which a packaged terminal system is sold by the Company to an Original Owner for use in a new facility to be constructed and located in the greater New York City metropolitan area. For the avoidance of doubt, except in the case described in the preceding sentence, the Company has no obligation under this warranty to provide for field labor or to make reimbursement of the labor or services charges of any other party, provided, however, that the Company, in its sole and absolute discretion, may elect to do so, so long as (i) such election is set forth in a writing signed by the Company and (ii) the facility at which the applicable packaged terminal system is or will be installed is located in the greater New York City metropolitan area (the "Metropolitan Area").

The obligations of the Company set forth in the preceding paragraphs of this Section are in all cases subject to the satisfaction of the following conditions: (x) the Company shall have received proof, satisfactory to the Company, of the purchase by the Original Owner from the Company of the packaged terminal system that is the subject of the Original Owner's claim, (y) all amounts due and payable to the Company on or prior to the date of such claim in respect of such packaged terminal system shall have been paid in full and (z) nothing shall exist or occur that relieves the Company, in accordance with the terms of this agreement, from the performance of its warranty obligations hereunder.

OPTIONAL Extended Refrigeration Circuit Warranty

2nd – 5th year compressor parts only; labor not included

The Optional Extended Refrigeration Circuit Warranty MUST be purchased from Ice Air within thirty (30) days from date of delivery to be valid. The hermetically sealed refrigeration circuit (consisting of the motor, compressor assembly, evaporator coil, coaxial / condenser coil, and interconnecting tubing) is warranted to the Original Owner for four additional years from date of the expiration of the twelve-month Warranty. Components under this warranty will be supplied at Ice Air's expense provided the failed component is returned to Ice Air. This optional warranty does not include any other parts of the equipment such as fans, fan motors, controls, cabinet parts, electrical relays, capacitors, protective devices, or wiring. Ice Air is not obligated under this warranty for field labor such as service for inspection, removing, packing, and/or reinstalling the refrigeration circuit, nor for return transportation charges. In addition, the Company is not obligated under this warranty to make reimbursement of the labor or service charges of any other party. Ice Air reserves the right to make a handling and inspection charge in the case of parts or equipment improperly returned as defective and/or as being in warranty.

To obtain assistance under the parts warranty or to purchase the optional extended warranty, simply contact Ice Air Customer Service at 80 Hartford Avenue, Mount Vernon, New York 10553 Phone 914-668-4700.

Additional warranty options include:

2nd – 5th year full unit parts only warranty

2nd – 5th year compressor parts and labor warranty, so long as such labor is performed in the NY Metropolitan Area

2nd – 5th year complete parts and labor warranty (Full unit coverage), so long as such labor is performed in the NY Metropolitan Area.

All Warranties (which must be purchased separately) constitute the Original Owner's sole remedy. They are given in lieu of all other warranties. Ice Air is not liable for incidental or consequential damages, whether the theory is breach of this or any warranty, negligence, or strict tort. No person (including any agent, salesman, dealer, or distributor) has authority to expand Ice Air's obligation beyond the terms of these express warranties, or to state that the performance of the product is other than that published by Ice Air. In addition, neither the Original Owner nor any such person has the right to sell, transfer or assign, or attempt to sell, transfer or assign, any rights of the Original Owner in or to the warranties provided for herein, no such sale, transfer or assignment shall be binding upon Ice Air and any such sale, transfer or assignment is null and void and of no force or effect.

General Conditions

The above warranties are void if Ice Air's equipment has been damaged, misused, subjected to abnormal use or service or its serial number has been altered, defaced, or removed, or payment for the equipment is in default. Ice Air is not responsible for service to correct conditions due to misapplication, faulty or improper installation, inadequate wiring, incorrect voltage conditions or unauthorized opening of the refrigeration circuit, nor for consequential damages. In case Ice Air's equipment is installed in conjunction with cabinets, grills, louvers, controls, or other parts manufactured by others, these warranties shall apply only to Ice Air's manufactured portion of the equipment. The conditions of the standard warranty plan are effective for 12 months from the date of equipment delivery. Ice Air reserves the right to make a handling and inspection charge in the case of parts or equipment improperly returned as defective and/or as being in warranty.

Important Disclaimers

Ice Air Has No Responsibility For:

(A) Certain Damages

The following are the responsibility of the user. None of the following constitutes a manufacturing defect, and each is expressly excluded from the warranty plan:

- 1) Failure of unit to operate satisfactorily due to improper amount of air on evaporator coil or air supply to air cooled condensers.
- 2) Damage to unit or unsatisfactory operation due to improper cleaning of evaporator coil or use of unit in corrosive atmosphere locations such as chemical plants, refineries, or salt spray areas.
- 3) Damage to unit from unsatisfactory operation due to blown fuses, inadequate or interrupted electrical service, use of improper electrical protective devices or operation of unit on power supply other than covered by nameplate rating of unit.
- 4) Damage due to failure to properly maintain unit.
- 5) Damage due to transportation or handling prior to and during installation.
- 6) Damage due to accident or from alteration, improper installation or tampering.
- 7) Failure to clean or replace filter timely.
- 8) Misapplication of equipment.
- 9) Damage due to deviation from original design and intended use of equipment.
- 10) Damage due to use of additional accessories either unapproved or approved but modified or manipulated.

(B) Installation

Ice Air is not responsible for the design, execution, and performance of the installation method or any of the accessory items used during installation such as seals, caulking, weatherproofing, supporting structures, attachment means, louvers and frames supplied by others.

(C) Check, Test and Start

Check, Test and Start of the air conditioners by an experienced person is the responsibility of the installing contractor. This consists of physically confronting each conditioner operating in both heating and cooling modes and correcting any minor deficiencies noted. After the equipment leaves the factory, it may become damaged or maladjusted during transportation or on the job. Sometimes wires are disconnected accidentally, or fan motors move on their bases due to rough handling, causing fans to strike; a component(s) may be inoperable. The correction of such conditions is part of the Check, Test and Start. Note that unless otherwise specifically agreed to in writing, Ice Air has no obligation to perform, nor does the price of its equipment include field labor in connection with the performance of, these Check, Test, and Start procedures (or the like).



80 Hartford Avenue, Mount Vernon, NY 10553

Tel: 877-ICE-AIR-1 (877-423-2471)

Fax: 914-668-5643

email: service@ice.air.com

www.ice-air.com

© 2023 by Ice Air, LLC

ICE6087.3 11/23