



Ice Air Electric Units

RSXC

RSXC-S

SPXC

HPWH

HPWH-SC

VSHPGE Geothermal

Electrification
Brochure

Contents

About Ice Air	2
Get Electrified Using Building Electrification and Ice Air	3
Electric Units	
RSXC Series	4
RSXC-S Series	6
SPXC Series	8
HPWH Series	10
HPWH-SC Series	12
VSHPGE Geothermal Series	14

About Ice Air

Ice Air has over 50 years of industry experience in developing and manufacturing a wide variety of HVAC units to provide superior new construction heating and cooling systems and to replace old installations. Ice Air offers advanced green technologies and provides world-class comfort at high efficiency levels, meeting environmental standards and promoting a healthy environment.

Ice Air's state-of-the-art units can be equipped with digital controls designed to optimize user comfort and ease of operation. Ice Air products are designed to provide years of trouble-free operation and reliable performance in multi-family housing, hotels/motels, dormitories, commercial buildings and similar projects. Units are ideal for new construction, retrofit and replacement applications.

Get Electrified Using Building Electrification and Ice Air

Whether driven by corporate policy or local greenhouse gas emission legislation, the movement to reduce carbon dioxide emissions – also known as decarbonization – is gaining momentum. As building owners explore ways to reduce reliance on fossil fuels and meet increasingly stringent environmental requirements, **building electrification** has emerged as a proven strategy for reducing emissions while increasing efficiency and lowering operating costs. Building electrification is the process of replacing existing technologies that rely on fossil fuels – such as space heating systems – with newer technologies such as heat pumps that use electricity as the energy source for both heating and cooling.

Numerous states around the U.S. – including California, New York, Washington DC, and others – have adopted regulatory policies aimed at reducing greenhouse gas emissions. Such regulations stress the role of electrification in decarbonizing the built environment and have wide-ranging implications for utilities, building engineers and architects, OEMs and building owners.

As an established HVAC original equipment manufacturer, Ice Air has been ahead of the of building electrification and decarbonization movement for decades. We're proud to leading the way and usher in a better tomorrow with innovative, reliable and efficient systems – all designed to help building owners make the transition to a greener, efficient and sustainable future.

RSXC Series, Page 4



RSXC-S Series, Page 6



SPXC Series, Page 8



HPWH Series, Page 10



HPWH-SC Series, Page 12



VSHPGE Series, Page 14



RSXC Series

Heat Pumps are Ready for the Cold

Ice Air RSXC Series Cold Climate PTHPs are efficient, sustainable, heat pumps designed for cold climate energy efficiency. Ice Air provides the best of both worlds – giving you the performance of a Variable Refrigerant Flow (VRF) system with the convenience of a PTAC.



Ice Air's RSXC models are AHRI certified. RSXC models include a variable speed compressor for optimal comfort. Heating performance is lab tested and certified down to -5°F, with a theoretical lower limit of -25°F for heating.



The RSXC Series complies with the NEEP Cold Climate Air Source Heat Pump (ccASHP) efficiency requirements. The Northeast Energy Efficiency Partnerships (NEEP) product listing identifies products best suited to electrify heating in cold climates.



The RSXC Series produce superior energy savings, which is especially important to satisfy the NYC Law 97 and other laws throughout the U.S., as well as helping projects comply with green building rating systems such as LEED®.



Rebates, incentives, and tax credits may be available through state, federal, and local utility programs.

For additional information scan the code → or visit: www.ice-air.com/rebates/



Ice Air RSXC units fit in a standard size wall sleeve (42-inches wide x 16-inches high) and use a sustainable R-410a refrigerant.

SPECIFICATION NOTES:

1. Rated performances in cooling mode @ 80°F/67°F DB/WB Indoors and 95°F/75°F DB/WB Ambient
2. Rated performances in heating mode @ 70°F/60°F DB/WB Indoors and 47°F/43°F DB/WB Ambient
3. Optional backup electric heat.

RSXC Series use advanced VRF technology to ensure the unit is pinpointing the exact amount of heating or cooling required for desired room conditions. The use of enhanced vapor injection (EVI) compressors allow Ice Air's PTHP units to operate to extreme low temperatures.

Eco-friendly: Operating in heat pump mode during the winter months without the need for electric heat, reducing emissions and energy consumption.

On-demand Operation: Variable speed compressors modulate output based on room demand.

Fresh Air: Outside air options are available for room conditioning.

Furniture-Grade Finish: Chassis is concealed by a steel enclosure with a beautiful baked powder coat finish.

Enhanced Control Options: Each RSXC unit comes standard with Habitat Wireless Thermostat with smart control capabilities.*

Features:

- R410A “green” refrigerant
- Highest levels of energy efficiency in the market
- Industry best sound levels
- Heating performance laboratory tested and certified to -5°F
- The theoretical lower limit for heating operation is -25°F ambient
- Fits within a standard size wall sleeve (42” W x 16”)

Series Model #	RSXC09	RSXC13	RSXC18
Cooling Capacity (Btu/h) ¹	9,200	12,500	16,300
Cooling Capacity Range (Btu/h)	6,300 - 11,800	6,500 - 14,900	7,300 - 18,000
EER ¹	12.1	11.1	10.0
Cooling Input (Watts)	760	1,126	1,630
Cooling Input (Amps)	3.7	5.4	7.8
Airflow (CFM)	380	400	480
Outside Air (CFM)	60	60	60
Heating Capacity (Btu/h) ²	10,200	12,000	17,300
Heating Capacity Range (Btu/h)	5,200 - 12,600	5,600 - 14,200	9,500 - 18,700
COP ²	3.6	3.1	3.0
HSPF ²	9.6	9.5	9.0
Heating Input (Watts)	830	1,134	1,690
Heating Input (Amps)	4.0	5.5	8.1
Voltage	208	208	208
MCA	5.9	8.5	10.4
MOP	15	15	15
Weights (lbs.)	127	134	151
LOW AMBIENT PERFORMANCE			
Heating Capacity @ 10°F	6,600	7,700	11,600
COP @ 10°F	2.2	2.14	2.02
Heating Capacity @ 5°F	6,100	6,900	10,600
COP @ 5°F	1.98	1.91	1.93
Heating Capacity @ -5°F	5,500	6,400	8,100
COP @ -5°F	1.74	1.62	1.6

* Smart app module must be purchased separately.

Due to Ice Air's ongoing product development programs, the information in this document is subject to change without notice.

RSXC-S Series

Heat Pumps are Ready for the Cold

Ice Air RSXC-S Series Cold Climate heat pumps are efficient, sustainable, heat pumps designed for cold climate energy efficiency. Providing the performance of a Variable Refrigerant Flow (VRF) system and the convenience of a packaged unit, the RSXC-S Series combines sophisticated technology with a sleek, compact footprint that complements any décor.

Heating using compressor only (no backup electric heat) down to -5°F, with a theoretical lower limit of -25°F.



The RSXC-S Series complies with the NEEP Cold Climate Air Source Heat Pump (ccASHP) efficiency requirements. The Northeast Energy Efficiency Partnerships (NEEP) product listing identifies products best suited to electrify heating in cold climates.



The RSXC-S Series produce superior energy savings, which is especially important to satisfy the NYC Law 97 and other laws throughout the U.S., as well as helping projects comply with green building rating systems such as LEED®.



Rebates, incentives, and tax credits may be available through state, federal, and local utility programs.

For additional information scan the code →



or visit: www.ice-air.com/rebates/



RSXC-S Series use advanced VRF technology to ensure the unit is pinpointing the exact amount of heating or cooling required for desired room conditions. The use of enhanced vapor injection (EVI) compressors allow Ice Air's cold climate heat pumps to operate to extreme low temperatures.

Eco-friendly: Operating in heat pump mode during the winter months without the need for electric heat, reducing emissions and energy consumption.

On-demand Operation: Variable speed compressors modulate output based on room demand.

Compact Design: Sleek, modern footprint blends seamlessly with any décor. Slim 9½ inch depth for aesthetic appeal.

Furniture-Grade Finish: Chassis is concealed by a steel enclosure with a beautiful baked powder coat finish.

Enhanced Control Options: Each RSXC-S unit comes standard with Habitat Wireless Thermostat with smart control capabilities.*

Features:

- R410A “green” refrigerant
- Highest levels of energy efficiency in the market
- Low noise transmission
- Slim, sleek design

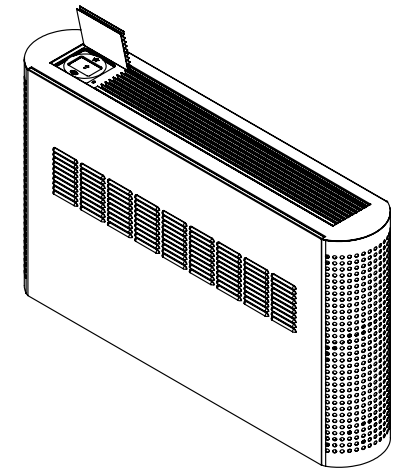

Ice Air's compact RSXC-S units utilize two 10-inch round wall openings to absorb and reject heat from the environment.

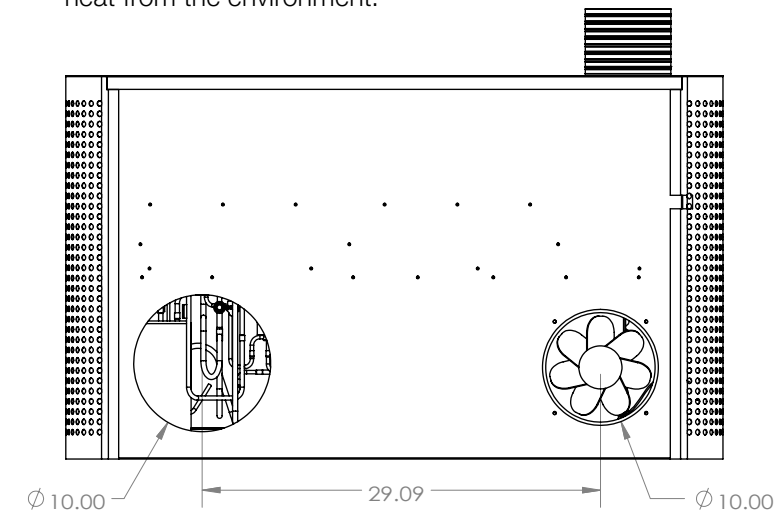

SPECIFICATION NOTES:

1. Rated performances in cooling mode @ 80°F/67°F DB/WB Indoors and 95°F/75°F DB/WB Ambient
2. Rated performances in heating mode @ 70°F/60°F DB/WB Indoors and 47°F/43°F DB/WB Ambient

* Smart app module must be purchased separately.

Due to Ice Air's ongoing product development programs, the information in this document is subject to change without notice.

Series Model #	RSXC09-S	
Cooling Capacity (Btu/h) ¹	7,500	
Cooling Capacity Range (Btu/h)	6,300 - 11,800	
EER ¹	11.0	
Heating Capacity (Btu/h) ²	7,500	
Heating Capacity Range (Btu/h)	5,200 - 12,600	
COP ²	3.5	
Voltage	115	208
Current in Cooling Operation (Amps)	5.9	3.3
Power in Cooling Operation (Watts)	682	
Current in Heating Operation (Amps)	5.5	3.0
Power in Heating Operation (Watts)	682	
MCA (without Electric Heat)	10.6	5.9
MOCP (without Electric Heat)	15	15
Evaporator Motor Nominal HP	1/25	1/25
Airflow (CFM)	380	
LOW AMBIENT PERFORMANCE		
Heating Capacity @ 10°F	6,100	
COP @ 10°F	2.00	
Heating Capacity @ 5°F	5,600	
COP @ 5°F	1.75	

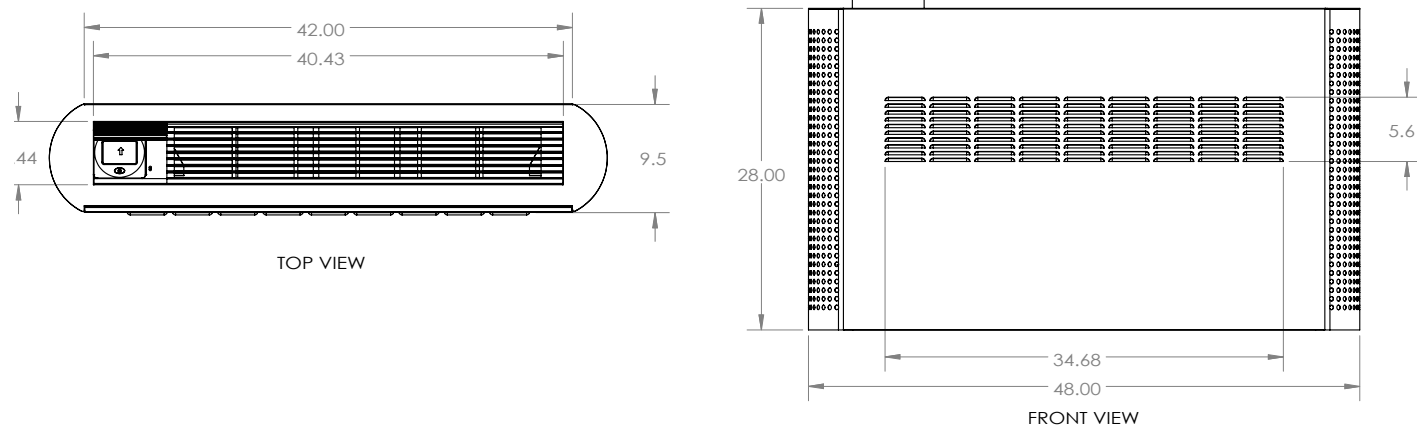

SPXC Series

Heat Pumps Beat the Cold

A perception persists that heat pumps can't hold up in extreme cold climates such as an Upper Midwest or New England winter. With the introduction of Ice Air's breakthrough cold climate technology, our line of SPXCs would allow for efficient heat pump operation on the coldest days.

Ice Air SPXC Series Cold Climate Single Packaged Heat Pumps (SPHPs) are efficient, sustainable, heat pumps designed for cold climate. Ice Air provides **the best of both worlds** – giving you the performance of a Variable Refrigerant Flow (VRF) system with the convenience of a packaged heat pump, while providing the benefits of a ducted system. SPHPs can be hidden in a closet or behind a wall and serve multiple spaces via concealed ductwork.

SPXC models include a variable speed compressor for optimal comfort. Heating performance is lab tested and certified down to -5°F, with a theoretical lower limit of -25°F for heating.



The SPXC Series complies with the NEEP Cold Climate Air Source Heat Pump (ccASHP) efficiency requirements. The Northeast Energy Efficiency Partnerships (NEEP) product listing identifies products best suited to electrify heating in cold climates.



The SPXC Series produce superior energy savings, which is especially important to satisfy the NYC Law 97 and other laws throughout the U.S., as well as helping projects comply with green building rating systems such as LEED®.



Rebates, incentives, and tax credits may be available through state, federal, and local utility programs.

For additional information scan the code → or visit: www.ice-air.com/rebates/



With Ice Air technology, cost-effective electrification for residential new build is possible even in cold climates.

SPECIFICATION NOTES:

1. Rated performances in cooling mode @ 80°F/67°F DB/ WB Indoors and 95°F/75°F DB/WB Ambient
2. Rated performances in heating mode @ 70°F/60°F DB/WB Indoors and 47°F/43°F DB/WB Ambient
3. Emergency backup electric heater is offered as a factory option.

SPXC Series use advanced VRF technology to ensure the unit is pinpointing the exact amount of heating or cooling required for desired room conditions. The use of enhanced vapor injection (EVI) compressors allow Ice Air's SPXC units to operate to extreme low temperatures.

Eco-friendly: The system operates in heat pump mode during the winter months without the need for electric heat, reducing emissions and energy consumption.

On-demand Operation: Variable speed compressors modulate output based on room demand.

Fresh Air: Outside air options are available for room conditioning.

Space-saving Design: Unit concealed in mechanical closet saving valuable floor space.

Enhanced Control Options: Each SPXC unit comes standard with Habitat Wireless Thermostat with smart control capabilities.*

Features:

- R410A "green" refrigerant
- Highest levels of energy efficiency in the market
- Supply air can be ducted for conditioning multiple rooms
- Heating performance laboratory tested and certified to -5°F
- The theoretical lower limit for heating operation is -25°F ambient
- Fully packaged chassis for self-contained conditioning

SERIES MODEL #	8SPXC12	8SPXC18	8SPXC24
Cooling Capacity (Btu/h) ¹	11,200	16,800	24,000
Sensible Capacity (Btu/h) ¹	9,900	12,900	18,500
Cooling Capacity Range (Btu/h)	9,700 - 15,700	10,500 - 19,500	13,900 - 25,600
EER ¹	13.0	11.0	11.0
Cooling Operating Range	38°F TO 115°F		
Cooling Input (Watts)	862	1,527	2,182
Cooling Input (Amps)	4.1	7.3	10.4
Heating Capacity (Btu/h) ²	11,400	15,200	21,000
Heating Capacity Range (Btu/h)	7,600 - 14,500	11,500 - 19,200	15,100 - 25,900
COP ²	3.5	3.3	3.3
HSPF ²	9.0	9.0	9.0
Heating Outdoor Operating Range	-5°F TO 70°F		
Heating Input (Watts)	955	1,350	1,865
Heating Input (Amps)	4.6	6.5	9.0
Electric Heat (kW)	3.5 5.0	5.0 7.5	5.0 7.5
Voltage	208	208	208
MCA (without Electric Heat)	9.8	14.8	18.8
MOP (without Electric Heat)	15	20	25
MCA (with Electric Heat)	22.5 27.8	28.7 47.4	28.9 47.8
MOP (with Electric Heat)	25 30	30 50	30 50
Airflow (CFM)	400	600	800
Weights (lbs.)	220	260	360

* Smart app module must be purchased separately.

Due to Ice Air's ongoing product development programs, the information in this document is subject to change without notice.

HPWH Series

Cold Weather and Your Water Heater

There's a better way to provide domestic hot water, and that's via cold climate heat pump water heaters (HPWH). This technology offers an energy-efficient means of heating water without the use of fossil fuels.

Ice Air's engineering enables HPWH units to operate at very high coefficients of performance in hot temperatures. Even in extreme cold, HPWH units provide a higher efficiency than natural gas boilers and electric resistance tanks.



The HPWH Series complies with the NEEP Cold Climate Air Source Heat Pump (ccASHP) efficiency requirements. The Northeast Energy Efficiency Partnerships (NEEP) product listing identifies products best suited to electrify heating in cold climates.



The HPWH Series produce superior energy savings, which is especially important to satisfy the NYC Law 97 and other laws throughout the U.S., as well as helping projects comply with green building rating systems such as LEED®.



Rebates, incentives, and tax credits may be available through state, federal, and local utility programs.

For additional information scan the code → or visit: www.ice-air.com/rebates/



Ice Air's HPWH Series are tested to -13°F providing hot water even when it is extremely cold outside.

Ice Air HPWH Series Cold Climate Heat Pump Water Heaters are designed to provide domestic hot water to large buildings on the coldest days – allowing domestic hot water generation with zero emissions.

- Defining Cold Climate
- Industry leading performance
- Lower cost of operation and maintenance compared to condensing gas-fired water heaters
- 4x more efficient compared to electric resistance heaters
- Multiple independent circuits provide built-in redundancy
- Double wall heat exchangers ensure occupant safety
- Optional single wall heat exchangers (for glycol applications)
- Freeze protection standard
- Optional heat-trace powered by building emergency power
- Clean out ports to remove sediment or lime deposits



SERIES MODEL #		ccHPWH275-D	ccHPWH550-D	ccHPWH275-S	ccHPWH550-S
Input Power		208-230V/3Ph/60Hz	208-230V/3Ph/60Hz	208-230V/3Ph/60Hz	208-230V/3Ph/60Hz
Refrigerant Circuits		2	4	2	4
Refrigerant / Quantity		R410A (30.8 Lbs / 15.4 Lbs per circuit)	R410A (61.7 Lbs / 15.4 Lbs per circuit)	R410A (30.8 Lbs / 15.4 Lbs per circuit)	R410A (61.7 Lbs / 15.4 Lbs per circuit)
Max H/W Temperature		140°F	140°F	140°F	140°F
Performance Specifications	Dry Bulb Temperature (68°F)	306,000	637,300	310,800	647,400
	Wet Bulb Temperature (59°F)				
	Inlet Water Temperature (59°F)				
	Outlet Water Temperature (131°F)				
	Heating Capacity (Btu/H)	306,000	637,300	310,800	647,400
	Input Power (kW)	21.4	45.0	20.7	43.1
	COP	4.20	4.15	4.40	4.40
	Dry Bulb Temperature (45°F)	248,000	516,600	251,900	524,800
	Wet Bulb Temperature (43°F)				
	Inlet Water Temperature (48°F)				
	Outlet Water Temperature (131°F)				
	Heating Capacity (Btu/H)	248,000	516,600	251,900	524,800
Input Power (kW)	22.0	45.9	21.4	44.6	
COP	3.30	3.30	3.45	3.45	
Dry Bulb Temperature (10°F)	160,300	333,800	162,800	339,100	
Wet Bulb Temperature (7°F)					
Inlet Water Temperature (43°F)					
Outlet Water Temperature (131°F)					
Heating Capacity (Btu/H)	160,300	333,800	162,800	339,100	
Input Power (kW)	22.4	46.6	21.7	45.2	
COP	2.10	2.10	2.20	2.20	
FLA (A)		106.4	212.8	103.7	204.4
MCA (A)		134.6	254.4	134.6	254.4
MOCP (A)		175	300	175	300
Sound Level (dBA)		≤73	≤75	≤73	≤75
Condenser Type		Double Wall BPX	Double Wall BPX	Single Wall BPX	Single Wall BPX
Water Side Pressure Loss (psig)		11.7	16.51	11.7	16.51
Rated Water Flow (GPM) (DB/WB:45°F/43°F, Inlet/outlet: 104°F/113°F)		59.4	118.9	59.4	118.9
Single pass delta-T (F) (OA_temp=68°F, LWT=131°F)		10.37	10.80	10.53	11.00
Piping Position (Refer to the electric box as front)		Rear	Rear	Rear	Rear
Piping Sizes		2" (DN50)	3" (DN80)	2" (DN50)	3" (DN80)
Minimum Ambient Operating Temperature (°F)		-13	-13	-13	-13
Overall Dimensions [L x W x H] (inches)		81 x 39 x 89	95 x 51 x 89	81 x 39 x 89	95 x 51 x 89
Net Weight (Lbs)		1,555	2,950	1,555	2,950

HPWH-SC Series

Technology for a Sustainable Future

New advances in heat pump chiller/heater technology allow air-source equipment to extract the environment’s energy down to very low ambient temperatures. By capturing energy in the environment and converting it to hot water using the refrigeration cycle, the Ice Air HPWH-SC Series provides a renewable, all-electric option that requires minimal energy consumption.

Ice Air’s proven engineering enables the HPWH-SC Series units to operate at temperatures as low as -13°F, providing code compliant supply temperatures even when outside temperatures drop. The combination of efficiency and low energy consumption makes the HPWH-SC Series a valuable addition to high-rise buildings in cold weather climates.



The HPWH-SC Series complies with the NEEP Cold Climate Air Source Heat Pump (ccASHP) efficiency requirements. The Northeast Energy Efficiency Partnerships (NEEP) product listing identifies products best suited to electrify heating in cold climates.



The HPWH-SC Series produce superior energy savings, which is especially important to satisfy the NYC Law 97 and other laws throughout the U.S., as well as helping projects comply with green building rating systems such as LEED®.



Rebates, incentives, and tax credits may be available through state, federal, and local utility programs.

For additional information scan the code → or visit: www.ice-air.com/rebates/



Ice Air’s HPWH-SC Series are tested to -13°F providing hot water even when it is extremely cold outside.

Ice Air’s heat pump water chiller/heaters convert free energy from the environment into hot water. These units are designed to provide hot water to large commercial buildings, even on cold days (-13°F).

- Industry leading performance:
 - Lower operating/maintenance costs compared to condensing gas-fired water heaters
 - 4x more efficient than electric resistance heaters
- Multiple independent circuits provide built-in redundancy
- Built-in heat exchangers
- Freeze protection standard
- Optional heat-trace powered by building emergency power
- Clean out ports to remove sediment or lime deposits



SERIES MODEL #	ccHPWH275-SC	ccHPWH550-SC		
Heat Exchanger Type	Single Wall Brazed Plate HXR	Single Wall Brazed Plate HXR		
Input Power	208-230V/3Ph/60Hz	208-230V/3Ph/60Hz		
Refrigerant Circuits	2	4		
Refrigerant / Quantity	R410A (30.8 Lbs / 15.4 Lbs per circuit)	R410A (61.7 Lbs / 15.4 Lbs per circuit)		
Max H/W Temperature	140°F	140°F		
Performance Specifications	Dry Bulb Temperature (95°F)	Cooling Capacity (Btu/h)	216,516	396,480
	Inlet Water Temperature (55°F)	Input Power (kW)	18.3	34.5
	Outlet Water Temperature (45°F)	COP	3.46	3.37
	Dry Bulb Temperature (45°F)	Heating Capacity (Btu/h)	270,645	495,600
	Wet Bulb Temperature (43°F)	Input Power (kW)	21.7	40.6
	Inlet Water Temperature (105°F)	COP	3.66	3.58
Outlet Water Temperature (115°F)				
Minimum Ambient Operating Temperature (°F)	-13	-13		
Max. Input Power (kW)	29.8	62		
FLA (A)	120.6	240.4		
MCA (A)	134.6	254.4		
MOCP (A)	175	300		
Sound Level (dBA)	≤71	≤76		
Water Data	Water Side Pressure Loss (psig)	8.1	7.25	
	Rated Water Flow (GPM)	73.4	129.6	
	Max Working Pressure (psig)	230	230	
	Piping Position (Refer to the electric box as front)	Rear	Rear	
	Piping Sizes	2"	3"	
Overall Dimensions [L x W x H] (inches)	81 x 39 x 89	95 x 51 x 89		
Net Weight (Lbs)	1,500	2,850		

VSHPG Series

Go Green. Go Geothermal.

Geothermal heating and cooling systems are one of the most environmentally-friendly ways to heat and cool your building. They don't produce any carbon dioxide or any other greenhouse gases that contribute both to your increased carbon footprint and air pollution.

Ice Air's VSHPG Vertical Stack Geothermal WSHPs have a low electricity demand, which in the course of a year could result in meaningful savings. The VSHPG is a versatile geothermal heat pump available in a range of sizes and configurations for convenient installation. Fully compatible with geothermal conditions, Ice Air's Vertical Stack Geothermal WSHP offer high efficiencies — up to 21 EER in cooling on select models — and provide an ideal solution for whisper quiet cooling and heating within a tight footprint.



Ice Air's VSHPG units are AHRI certified, meet all UL standards and conform to ASHRAE 90.1, local building codes and energy standards. Ice Air's AHRI Performance Certified VSHPG models meet AHRI tier 1 efficiencies.



The VSHPG Series complies with the NEEP Cold Climate Air Source Heat Pump (ccASHP) efficiency requirements. The Northeast Energy Efficiency Partnerships (NEEP) product listing identifies products best suited to electrify heating in cold climates.



The VSHPG Series produce superior energy savings, which is especially important to satisfy the NYC Law 97 and other laws throughout the U.S., as well as helping projects comply with green building rating systems such as LEED®.



Meets Energy Star Tier 1 efficiency ratings and qualifies for the Inflation Reduction Act (IRA) tax credit. Other rebates, incentives, and tax credits may be available through state, federal, and local utility programs.

For additional information scan the code → or visit: www.ice-air.com/rebates/



Ice Air's full Water Source Heat Pump line includes Console WSHPs, Horizontal WSHPs, Vertical Closet WSHPs & Vertical Stack WSHPs.



Because the system works with the relative temperature of the earth instead of the variable temperatures above ground, geothermal heating and cooling systems use 40-60% less energy than conventional systems. In addition to offering energy cost savings, Ice Air geothermal systems provide many other benefits, such as:

Eco-friendly: The system uses ground heat, which is renewable and pollution-free.

Quieter operation: Designed to provide quiet operation.

Improved air quality: Geothermal systems offer fewer threats to indoor air quality – a benefit for everyone, especially those with asthma or allergies.

Longevity: A geothermal system can run for decades.

Features:

- R410A “green” refrigerant
- Highest efficiency in market
- 17.1+ EER
- 3.6+ COP
- Advanced controls on every unit
- Industry best sound levels

SERIES MODEL #	8VSHPG09	8VSHPG12	8VSHPG15	8VSHPG18	8VSHPG24	8VSHPG30
Cooling Capacity (Btu/h)	11,000	13,800	15,000	19,500	24,800	30,000
Sensible Capacity (Btu/h)	9,500	10,800	12,100	15,400	18,600	24,000
EER	21.3	20.1	17.5	18.7	18.4	17.3
Heating Capacity (Btu/h)	6,500	9,000	10,500	13,400	17,000	21,900
COP	3.64	3.7	3.7	3.63	3.66	3.6
Flow Rate (GPM)	2.3	3	3.8	4.5	6	7.5
Air Flow (CFM)	460	500	560	620	800	1000
Voltage/Hz/Ph	208-230/60/1					
Compressor RLA	3.25	4.1	5.5	6.1	9.15	11.25
Compressor LRA	20	27	28.5	35.6	43	62
Fan Motor FLA	2					3.98
MCA	6.6	7.6	9.4	10.1	13.9	19
MOP	9.3	11.2	14.4	15.7	22.6	29.3
Fuse Size	15				20	25

SPECIFICATION NOTES:
 COOLING CAPACITY BTUH RATED AT @ 80.6°F, 66.2°F WB EAT 77°F EWT @ 3 GPM/TON
 HEATING CAPACITY BTUH RATED AT @ 68°F DB, 59°F WB EAT, 32°F EWT @ 3 GPM/TON

The performance data shown above is based on standard equipment under the provided design conditions. Performance may vary depending on equipment configuration and project site conditions.

Electrified Product Family



* By making energy-saving upgrades today, you can give your building a head start on upcoming changes to city regulations such as NYC Law 97.

RSXC Series*

Cold Climate PTHPs give you the performance of a VRF system with the convenience of a PTAC. Using breakthrough cold climate technology allows Ice Air PTHPs to efficiently provide space heating down to -5°F and below.



RSXC-S Series*

Ice Air's RSXC-S Series Cold Climate heat pumps offer a slim, sleek design and efficiently provide space heating to -5°F and below.



RSXC-DH Series*

RSXC-DH air source heat pumps are compact, with advanced, two-stage dual heating capabilities (partial cold climate operation down to 23°F then supplemental electric heat resistance for increased output).



SPXC Series*

Cold Climate SPHPs are self-contained, concealed, ducted systems. This line of vertical packaged heat pumps serves multiple spaces through concealed ductwork to efficiently provide space heating to -5°F and below.



HPWH Series*

Air-Source Cold Climate Heat Pump Water Heaters capture the free energy in the environment and convert it to hot water. These units are certified to operate down to -13°F.



HPWH-SC Series*

Air-Source Cold Climate heat pump chiller heaters capture free energy in the environment to provide both hot and chilled water. These units are certified to operate down to -13°F.



VSHPGE Geothermal*

Ice Air's Geothermal WSHP is a versatile geothermal heat pump that is available in a range of sizes and configurations for convenient installation. Fully compatible with geothermal conditions, it provides an ideal solution for whisper quiet cooling and heating within a tight footprint.



ICE AIR VRF

New technologies like Variable Refrigerant Flow (VRF) are on the move. There is no denying the benefits of VRF any longer, and with Ice Air VRF, these benefits are delivered simply and effectively.



Other Products

FCU

Fan Coil Units

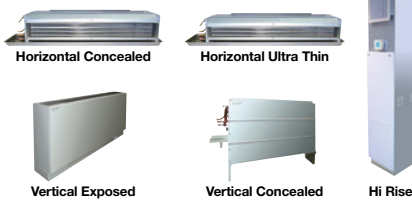

This simple and easy cooling and heating solution provides reliable performance, high efficiency, ease of operation, low cost, easy installation, quiet comfort and a variety of solution-based options.

HWCAC

Hybrid Water-Cooled Air Conditioners



HWCACs provide hydronic heat without using the unit's compressor through an innovative system that combines high-efficiency cooling with a hot water coil.

WSHP

Water Source Heat Pumps



WSHPs provide efficient room-by-room comfort. Units function independently and are piped to a central water loop.

PTAC

Packaged Terminal Air Conditioners

PTACs are designed for ultra-high efficiency and comply with LEED® criteria in a durable, user-friendly package. Available for new construction, retrofit and ExactFit™ replacement applications.



NEW! Ice Air CEU Webinar

Learn more about the role HVAC electrification plays in building decarbonization today at www.iceairceu.com.



80 Hartford Avenue,
Mount Vernon, NY 10553
Tel: 877-ICE-AIR-1 (877-423-2471)
Main: 914-668-4700
Fax: 914-668-5643
email: sales@ice-air.com
www.ice-air.com